

**Your first goal: is to build  
Your “First Team” quickly!**

**Enroll 3! Get3! (3 + 3)**

**Personally enroll 3,  
AND have 3 others in any combination.**

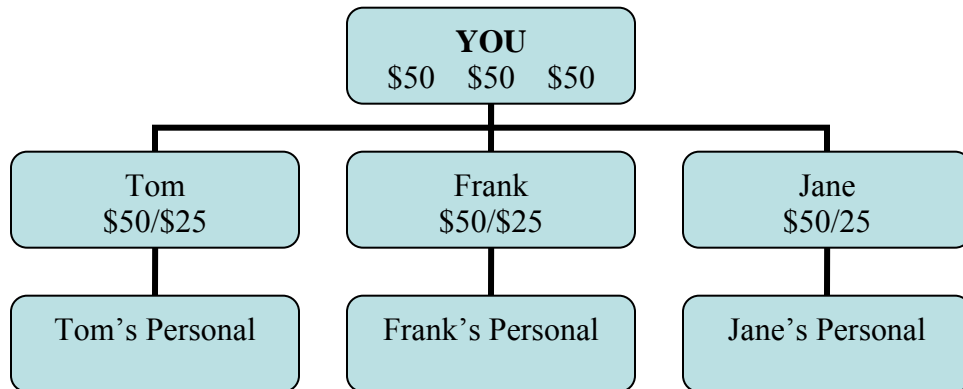

**Enroll 6 “personals”** and earn your original investment back, and receive your travel website **FREE** each month, paid for by company, **no more monthly charges!**

**When you personally enroll 3 people, you will earn a 50% matching bonus on each of your “personals”. When you complete your “First Team” you are allowed to move to your own “Power Team” where you will receive: \$100 for each personal RTA and \$50 for everyone else in your “Power Team” to infinity. You will receive a 50% matching bonus on all your “personals” in your “Power Team” through infinity and you will also earn booking commissions, other bonuses and residuals.**

**Your “Power Team”**

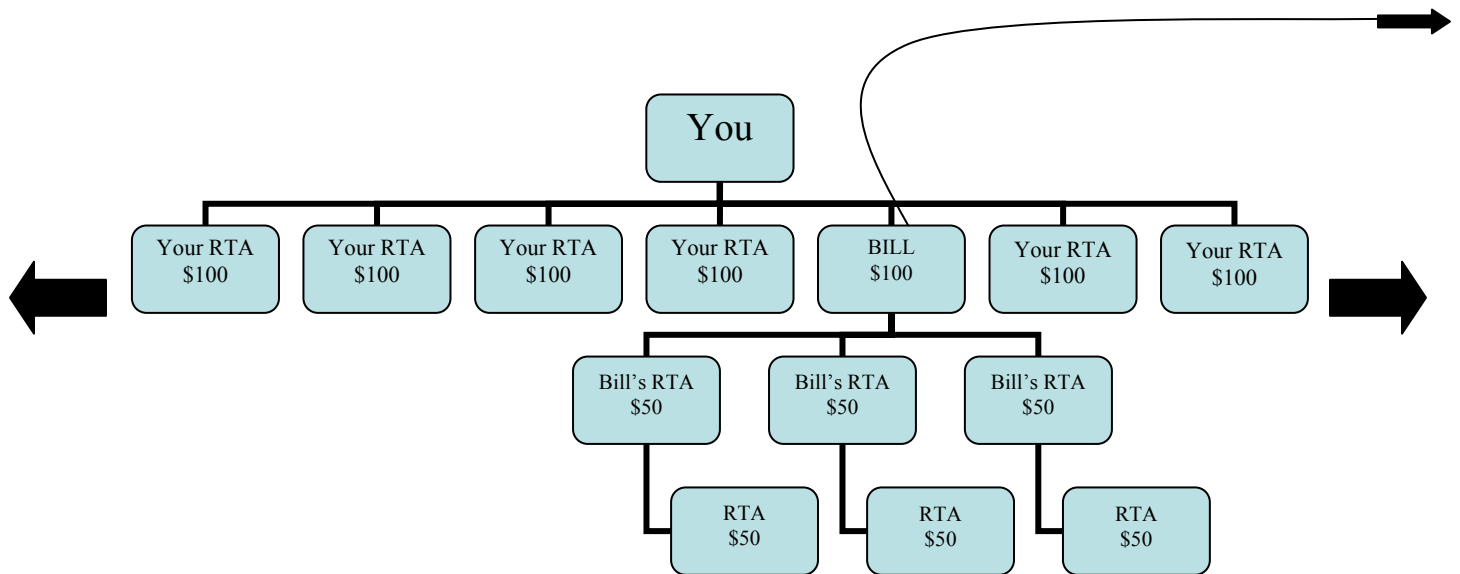

### Your “Power Team” Benefits:

1. You receive **\$100** for every personal RTA. (Referring Travel Agent).
2. You receive **50% matching income bonus** on **all your personal RTA’s to infinity!**
3. You receive **\$50** for everyone else in your “Power Team” to infinity!
4. Every time 6 RTA’s enter your “Power Team”, you earn a **\$1,000 bonus!**
5. Every 100 RTA’s in your “Power Team” earns you a **\$10,000 bonus!**
6. At 500 RTA’s you receive **1 unit** of the Director’s Pool (Profit sharing = \$2,000 min. per month, plus Major Med + Life Ins.)
7. 2,000 RTA’s earns you a **\$50,000 bonus.**
8. Also at 2,000 RTA’s you earn **2 units** of the Director’s Pool.
9. 5,000 RTA’s earns you a **\$100,000 bonus.** Plus all other bonuses!
10. Also at 5,000 RTA’s you earn **3 units** of the Director’s Pool.
11. 10,000 RTA’s earns you a **\$250,000 bonus.** Plus all other bonuses!
12. Also at 10,000 RTA’s you earn **4 units** of the Director’s Pool.
13. At 25,000 RTA’s you earn a **\$1,000,000 bonus.**
14. 25,000 RTA’s also earns you **5 units** of the Director’s Pool.

**How long will you take to get your first 6 RTA’s? Your second 6? Your third 6?**

*Upon completing his “First Team”, Bill moves to his own “Power Team” and Bill becomes your “First Generation” on your “Dream Team”. You earn \$30 on everyone in Bill’s “Power Team” to infinity plus a 50% matching income bonus.*

## Bill's "Power Team" is: Your "First Generation" "Dream Team"

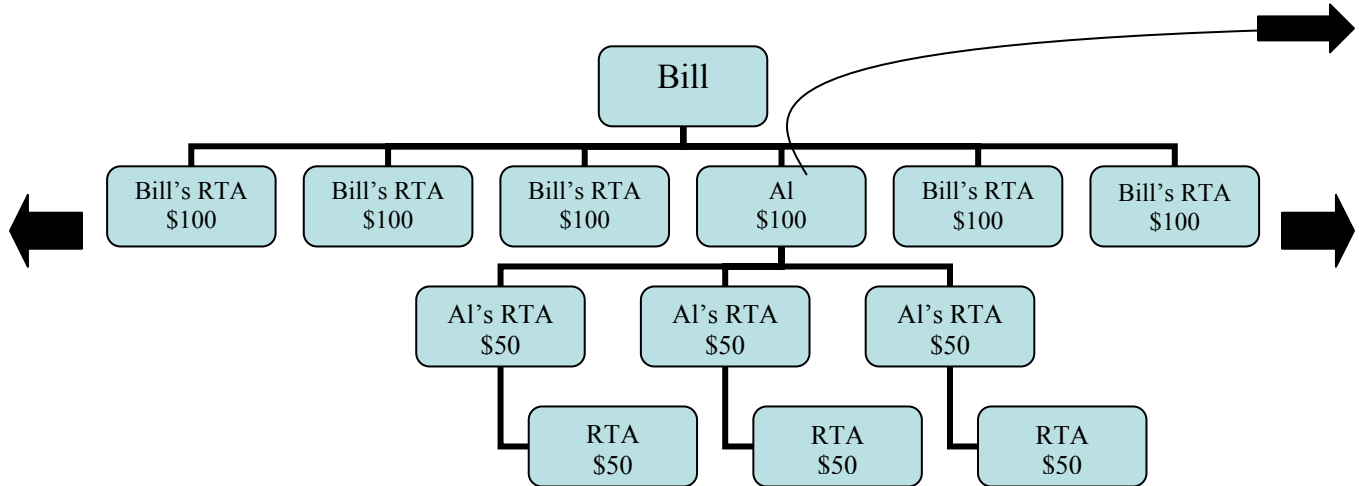

### Bill wants the bonuses and is building fast!!!

- You receive \$30 for everyone in Bill's "Power Team", plus a 50% matching income bonus. Bill, like you in your Power Team, receives \$100 for his "personals" on his "Power Team". With your 50% match bonus you get \$50 plus \$30 for everyone in Bill's team, so you receive \$80 every time Bill enrolls a "personal".
- Bill also receives \$50 on everyone else in his group. Your 50% match = \$25 + \$30, so you earn \$55 for everyone in Bill's group to infinity.

*Al moves to his own "Power Team", once he completes his "First Team". Al then becomes your "Second Generation" on your "Dream Team" and you earn \$20 for everyone in his PowerTeam to infinity.*

**"Dream Team" Earnings through 6 Generations:**

a

- 1<sup>st</sup>. Generation = \$30 on every RTA to infinity.  
Plus: For each "personally" enrolled "Power Team" = 50% matching income bonus.
- 2<sup>nd</sup> Generation = \$20 on every RTA to infinity.
- 3<sup>rd</sup> Generation = \$10 on every RTA to infinity.
- 4<sup>th</sup> Generation = \$5 on every RTA to infinity.
- 5<sup>th</sup> Generation = \$5 on every RTA to infinity.
- 6<sup>th</sup> Generation = \$5 on every RTA to infinity.

Two key questions always seem to come up over time and I thought I should address them both right here --- right now.

How much can I make?

How fast can I make it?

First, for the record, let me state right up front --- a lot depends on how much effort you want to put into it. That's true in any business, right?

But here's some good news...

Our pay plan was **designed by distributors for distributors** to ensure long term healthy growth in your business. It is designed for depth which experienced pros appreciate ...yet has plenty of bonus features built in for people who are new to Referral Marketing.

For the experienced pro - you want to know it pays you a **“Fast Start” Bonus** for “anyone” who is enrolled in your group to infinity, whether you enroll them or someone else does.

There is a **weekly 50% matching bonus** on each of your personal enrollees. Whatever “they” earn in a week...you earn an additional 50% matching check!

For **every six people joining your “Power Team”**, whether you or some one else enrolls them, **you receive \$1300-\$1600**. That's **every time**, there is 6: 6, 12, 18, 24 etc. When you reach 100, and every time you reach a new 100, **you receive an additional \$10,000 bonus!** Plus, there is world-wide **profit sharing**, and other **cash bonuses**, ranging from **\$50,000 to \$1,000,000! Yes, it's true!**

Helping 6 people, you personally enroll, can earn you more money in a short period of time than most people are earning working for some else, full time --- just 6. Imagine!

Basically what this means is you are encouraged each step of the way to help the people you introduce to this wonderful company, and extravagant pay plan.

The matching bonus gives you even more incentive to help your personal referrals succeed!

**Visit my website:**

Need more info? Give me a call and we'll go through everything together.

6 months down the road, you'll be thanking your lucky stars you made the wise move to be a part of this growing opportunity.

What an opportunity!